

# BlastMatic II

Model No.  
B-100

By **LSP** INDUSTRIES, INC.  
Rockford, Illinois

## DELAY TIME

FROM THE TIME UNIT IS  
TRIGGERED TO THE TIME  
BLOW-OFF BEGINS

DELAY  
TIME  
SET

## ACTUATION

FROM THE TIME BLOW-OFF  
BEGINS TO THE TIME  
BLOW-OFF ENDS

ACTUATE  
TIME  
SET

MANUAL  
CYCLE

PRESS TO  
SIMULATE  
TRIGGERING

MANUAL  
ACTUATION

POWER ON

# The BlastMatic® II

The ultimate selection  
for parts ejection.

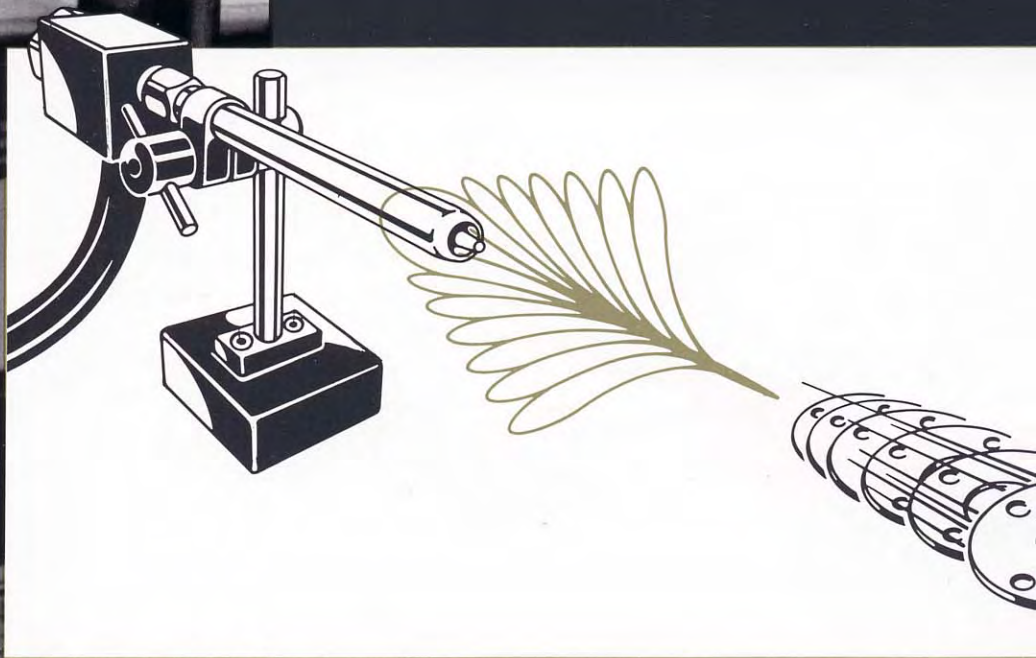

An electronic parts ejection system that  
increases your efficiency by reducing set-up  
time, shop noise and utility costs.

**LSP** INDUSTRIES, INC.  
Rockford, Illinois

# The BlastMatic II

- Conserves Air
- Solid State Electronics
- Reduces Setup Time

The BlastMatic II is a totally new concept in Electronic Parts Ejectors. By using the BlastMatic II Electronic Controls you tab in the precise instant during the Press cycle when a blast of air is to come on as well as the length of time the air stays on to insure that the part is safely ejected from the die area. Costly, unscientific trial and error cam adjustments are a thing of the past.

## Here's How It Works!!!

A magnet is mounted on the fly wheel or the crank shaft so that it makes one revolution per cycle of

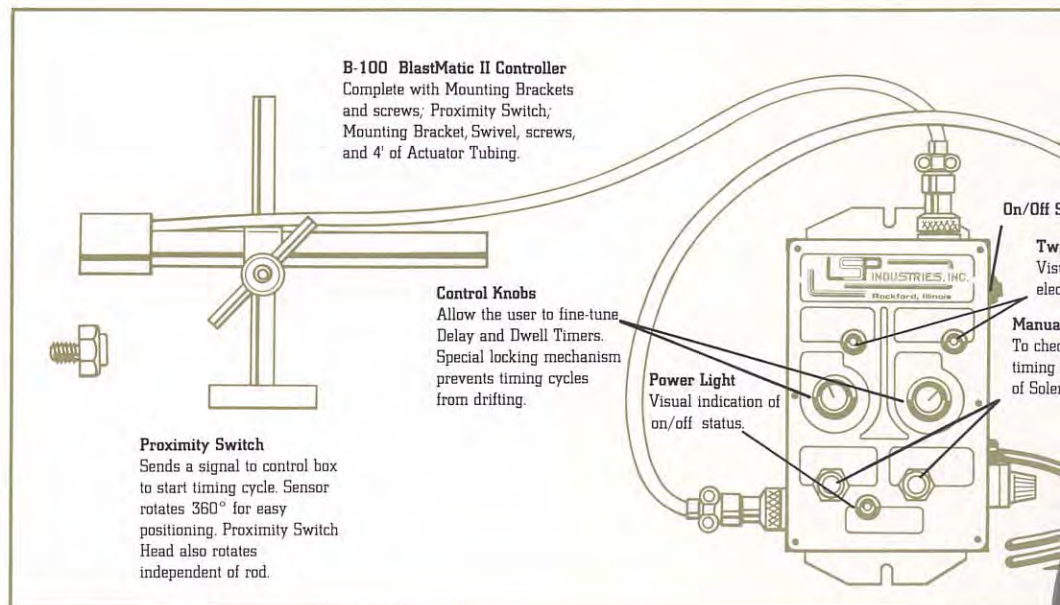

the press. The Proximity Switch is located so that it picks up a signal when the Magnet passes by it and sends the signal to the Electronic Controller. The signal activates the Delay Timer which, after a set period of time, activates the Dwell Timer. The Dwell Timer opens the Solenoid Valve and holds it open until it completes its cycle. The Solenoid Valve now sends a signal to the UniValve portion of the nozzle via the Actuator Tubing. On the next pass of the Magnet the cycle will repeat itself.



# The BlastMatic II Nozzles

- Quick Adjustability
- Quiets Work Area
- Focuses Air Stream

The BlastMatic Nozzle Assemblies are designed to deliver the precise amount of air necessary to eject a part out of the die like no other nozzle on the market today. Because the BlastMatic Nozzles are located only 6" from the LSP high Volume UniValve the system is pressurized immediately; there is no time or air waste. The unique Silent Nozzle Assemblies not only reduce noise, they also reduce air consumption. As the air exits the Nozzle, surrounding air is drawn into the exiting air stream, thus adding extra impact without the expense of additional shop air.

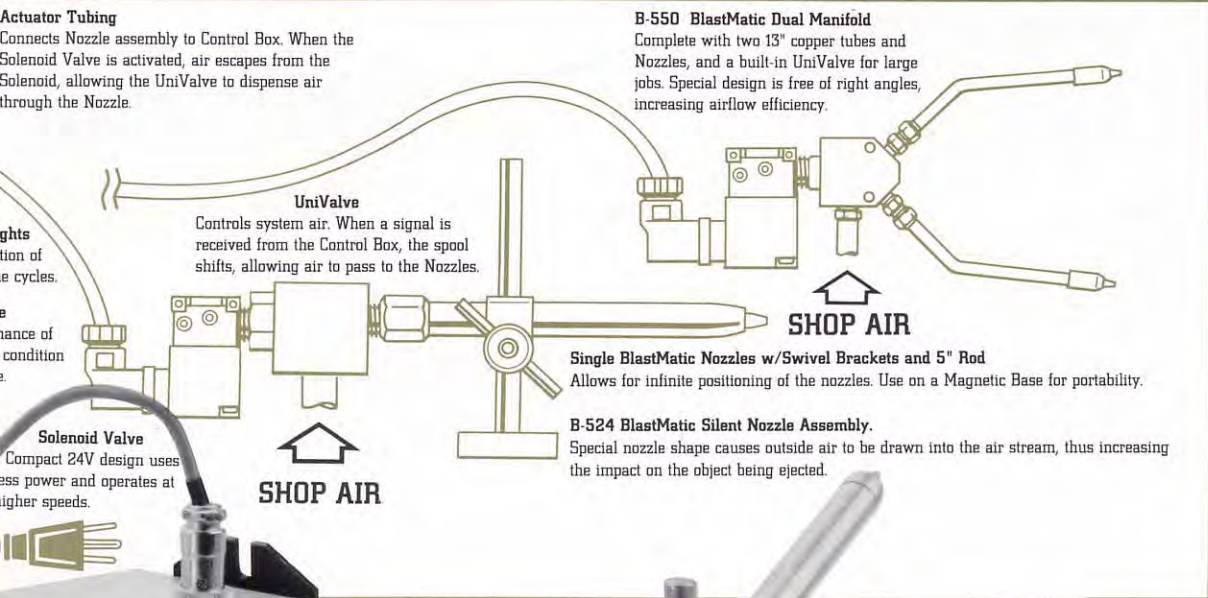

## Here's How It Works!!!

The BlastMatic nozzle can be permanently installed or mounted on a Magnetic Base for portability. Attach Shop Air into the inlet on the UniValve. The Actuator Tube is attached

between the UniValve and the Solenoid Valve on the BlastMatic II Electronic Controls. The instant the Solenoid Valve receives a signal the UniValve opens and allows air to pass through and out the Nozzle. When the Solenoid Valve loses its signal the UniValve goes into the rest mode.

Aim the Nozzle at the blow-off area, and you have access to an instantaneous blast of highly concentrated air with maximum work potential.



*Magnetic Base Optional*

# The Basic BlastMatic

- Installs In Minutes
- Economical Alternative
- Portable

The BlastMatic line offers an air ejection system for every application, from the extremely sophisticated to the very basic. The Basic BlastMatic is an effective, economical alternative to the BlastMatic II, using some of its components, less the electronic controls.

In operation, the Basic BlastMatic receives a signal from the Actuator Switch or Solenoid Valve.

## Here's How It Works!!!

When the Actuator Switch whisker is moved, or the Solenoid Valve receives an electrical impulse,

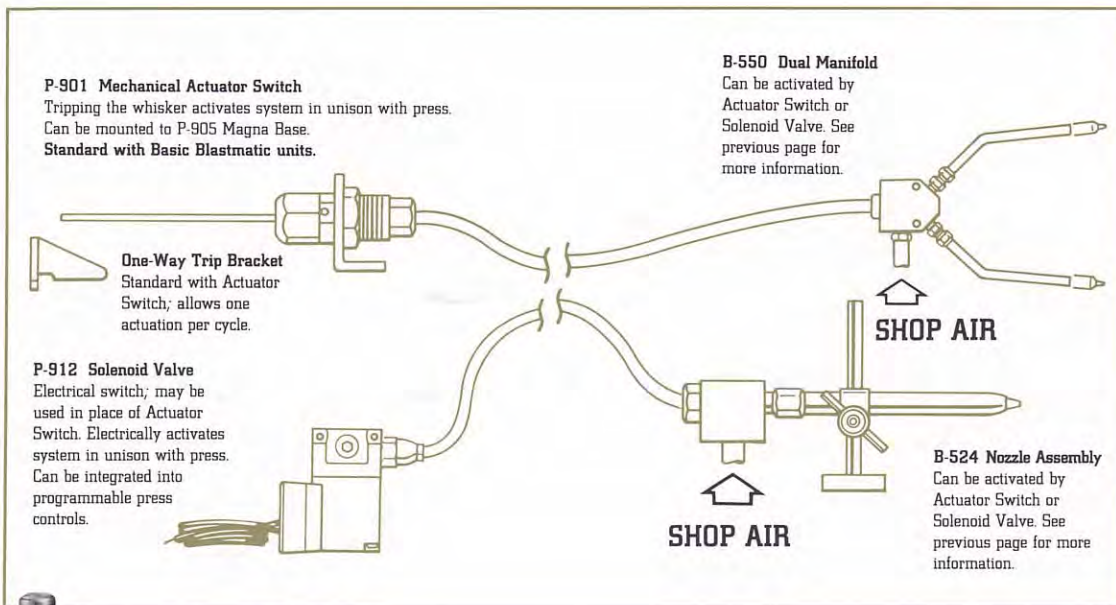

they activate the UniValve by the BlastMatic Nozzle or Manifold to dump the air through the Nozzles. The One-Way Trip Bracket, when used with the Actuator Switch, causes the system to operate in only one direction during the press cycle

eliminating double actuation. The BlastMatic II is the most efficient and economical way to eject parts from the die area.



# A New Concept

BlastMatic II Controller makes complete control of your shop's air blow-off system a reality! Blow-off cycle, time sequence and duration can be quickly adjusted with a reliable system that is compact, user-friendly and energy-efficient. The comprehensive system reduces set-up time and utility costs while increasing compressor life and employee satisfaction.

Addition of the BlastMatic II Nozzle assembly creates even greater savings; not only are time

The chart below demonstrates air savings realized by BlastMatic II, vs. a conventional blow-off.

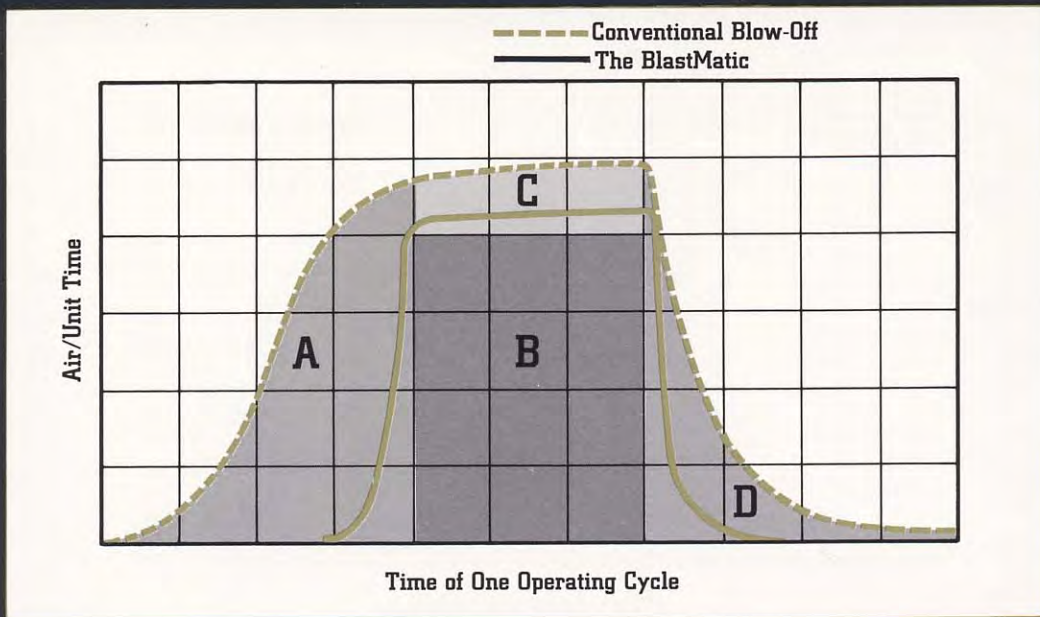

cycles controlled, the unique Nozzle uses incoming shop air more efficiently.

BlastMatic II was developed by LSP Industries, Inc., a pioneer in air ejection since 1975. This new design is the result of years of product research, development, and customer input.

**Area A:** Air expended bringing the system up to force. The BlastMatic II shows a marked decrease in air use, because it is valved on/off at the unit. There is no larger air line to fill before the system is pressurized.

**Area B:** Air required to do the job. This area represents the absolute smallest volume of area needed to eject the part; the minimum required if every bit of expelled air could contact the part at full force.

**Area C:** Air wasted due to inefficiencies. The BlastMatic II is shown to be more effective because of its focused air stream, which produces a highly concentrated blast.

**Area D:** Again, the BlastMatic II uses less air because there is no lengthy air line to be exhausted of unusable air. Only the small amount of air in the tube is used.

# Accessories & Specifications



**P-905 Magna Base**  
Adapts to the BlastMatic Ejector, BlastMatic Manifold, Proximity Switch, Actuator Switch, and One-Way Trip Bracket



**B-909 Magna Base (2X Strength)**  
Twice as large as P-905 magnet, with two 10/32" tapped holes.

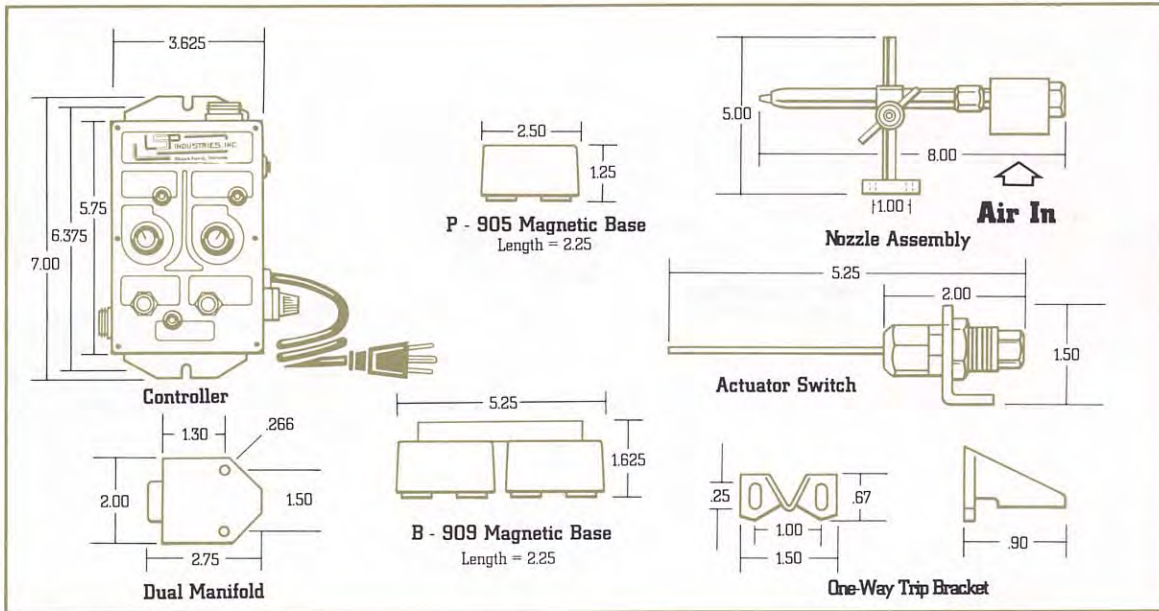

**P-912 Solenoid Valve**  
A 110 volt solenoid that attaches to the Basic BlastMatic. This solenoid is wired directly into the press cycle or programmable press control.

Distributed By:



**B-020 Nozzle Tip**  
Use on special applications; adapts to any pipe with a 1/8" female NPT. Nozzle tip only with 1/8" male NPT.



**B-030 Nozzle Tip**  
Use on special applications; adapts to any pipe with a 1/4" female NPT. Nozzle tip only with 1/4" male NPT.



P.O. Box 5303, 2511-20th St.  
Rockford, Illinois 61125  
Ph: 815/226-8090 Fax: 815/226-9250