

## RESERVOIR UNIT PARTS (continued)

Following Parts are Common to all Reservoir Units

Key No.	Part Number	Qty Used	Part Name or Description of Item
06	NUT-062	1	NUT, Jam: 3/4-16 UNF
07	RGO-060	1	RING, Seal: "O" type
08	OUT-010	1	OUTLET, Drain: reservoir
09	FIT-058	1	FITTING, Plug: 3/8" pipe
10	NUT-161	1	NUT, Special: jam
11	RGO-056	1	RING, Seal: "O" type
12	OUT-040	1	OUTLET, Fluid: reservoir
13	FIT-057	2	FITTING, Elbow: barbed
14	FIL-018	1	FILTER, Fluid:
15	NUT-058	2	NUT, Hexagon: 3/8-24 UNF
16	RGO-030	2	RING, Seal: "O" type
17	INL-026	1	INLET, Sight: top
18	RGO-013	2	RING, Seal: "O" type
19	OUT-009	1	OUTLET, Sight: bottom
20	RGO-034	1	RING, Seal: "O" type
21	PLG-026	1	PLUG, Sight: bottom
22	BRK-072	4	BRACKET, Threaded:
23	RGO-017	4	RING, Seal: "O" type
24	WAS-003	6	WASHER, Flat: 1/4"
25	NUT-051	4	NUT, Hexagon: 1/4-28 UNF
26	NUT-104	4	NUT, Hexagon: self lock
27	BRK-039	1	BRACKET, Mounting: air inlet
28	ADP-073	1	ADAPTER, Fitting: air inlet
29	NUT-063	1	NUT, Special: jam
30	SCR-075	2	SCREW, Cap: 1/4-20

Key No.	Part Number	Qty Used	Part Name or Description of Item
31	FIT-112	1	FITTING, Elbow
32	FIT-036	1	FITTING, Nipple
33	REG013	1	REGULATOR, Air
34	GAU-001	1	GAUGE, Air
35	FIT-111	2	FITTING, Adapter: 1/4" NPTx3/8" Push In
36	BLK-002	A/R	TUBING, Plastic: 3/8" O.D.
37	FIT-108	2	FITTING, Adapter: 1/4 NPT" X 1/2" OD tube
38	BLK-005	A/R	TUBING, Bulk: 1/2" O.D.
39	WAS-001	6	WASHER, Lock
40	SCR-105	2	SCREW, Cap: 10-24
41	SCR-108	4	SCREW, Cap: 10-24
42	VAL-009	1	AIR, Mechanical
43	FIT-107	2	FITTING, Adaptor:1/8" NPTx3/8 Push In
44	VAL-008	1	VALVE, Solenoid
45	ZCN-013	1	CONNECTOR VALVE, 3 Prong
46	SCR-107	2	SCREW, Button Hd #8
47	WAS-024	2	WASHER, Flat: #8
48	FIT-103	2	FITTING, Connector: 1/8" NPT X 1/4 tube
49	BLK-001	A/R	TUBING, Bulk: 1/4" O.D.
50	TUB-017	1	TUBING, Plastic; 1/2" I.D.
51	FIT-086	1	FITTING, Barb
52	FIT-109	1	FITTING, Elbow: (M) (F)
"C"	FC-7310	1	Transfer Pump: see NOTE below

**NOTE:**  
See the supplemental **INSTRUCTION BOOKLET** supplied for the "FC-7310" Pump (key # "C" above). It provides detailed information on the pump's usage, and includes an exploded view and parts listing.

## TROUBLESHOOTING INSTRUCTIONS

PROBLEMS	SOLUTIONS
I. No lubricant to any of the rolls.	A. Check the controller. 1. Hold hand on solenoid to feel actuation when controller receives a signal. If solenoid does not receive a signal. a. Solenoid may be bad b. Proximity switch may be misaligned or broken. c. Controller may be broken and not receiving or sending a signal. B. Check the diaphragm pump. 1. Air pressure may have been lost. 2. Diaphragm pump may be hung up.
II. The coil stock is coming out or the FloaterCoater with dry stripes .	A. One of the manifolds is plugged. 1. Remove the tube from the manifold. 2. Remove the fitting from the manifold. 3. Blow air in the reverse direction that the lubricant flows. 4. Check and make sure that the hole is free and reassemble the lines.
III. Lubricant continues to flow in between cycles & in the rest mode.	A. Check the solenoid to see if it has to be replaced. B. Check the controller to see if it is broken and in the open position.
IV. Lubricant has become gummy in the FloaterCoater.	A. Remove rolls, clean and purge the FloaterCoater with water or solvent. B. Clean the rolls and reassemble the FloaterCoater. <i>This is caused when changing from oils or water solubles to synthetics. To avoid this problem, purge the system prior to filling with lubricants that are incompatible.</i>
V. Not enough lubricant being dispersed onto the coil stock.	A. Is the controller set to stay open long enough to get a complete coating on each cycle of the feeder. B. Smooth rolls give the finest coating. A course roll will leave a much heavier coating.
VI. Too much lubricant being dispersed on the coil stock.	A. If large quantities of lubricant is being returned to reservoir, the open time on the controls is ope for too long a time. B. Try a smooth roll to reduce the amount of lubricant transferred to the coil stock.

## INSTALLATION, OPERATION, and TROUBLESHOOTING

with REPLACEMENT PARTS LISTING for  
FloaterCoater Model Nos. FC-1160-A & FC-1172-A  
Reservoir Model Nos. FC-7314, -7318, & -7320



P.O.Box 5303, Rockford, IL • 61125  
5060-27th Ave, Rockford, IL • 61109  
Tel: 815-226-8090 • Fax: 815-226-9250  
E-mail: sales@lspind.com

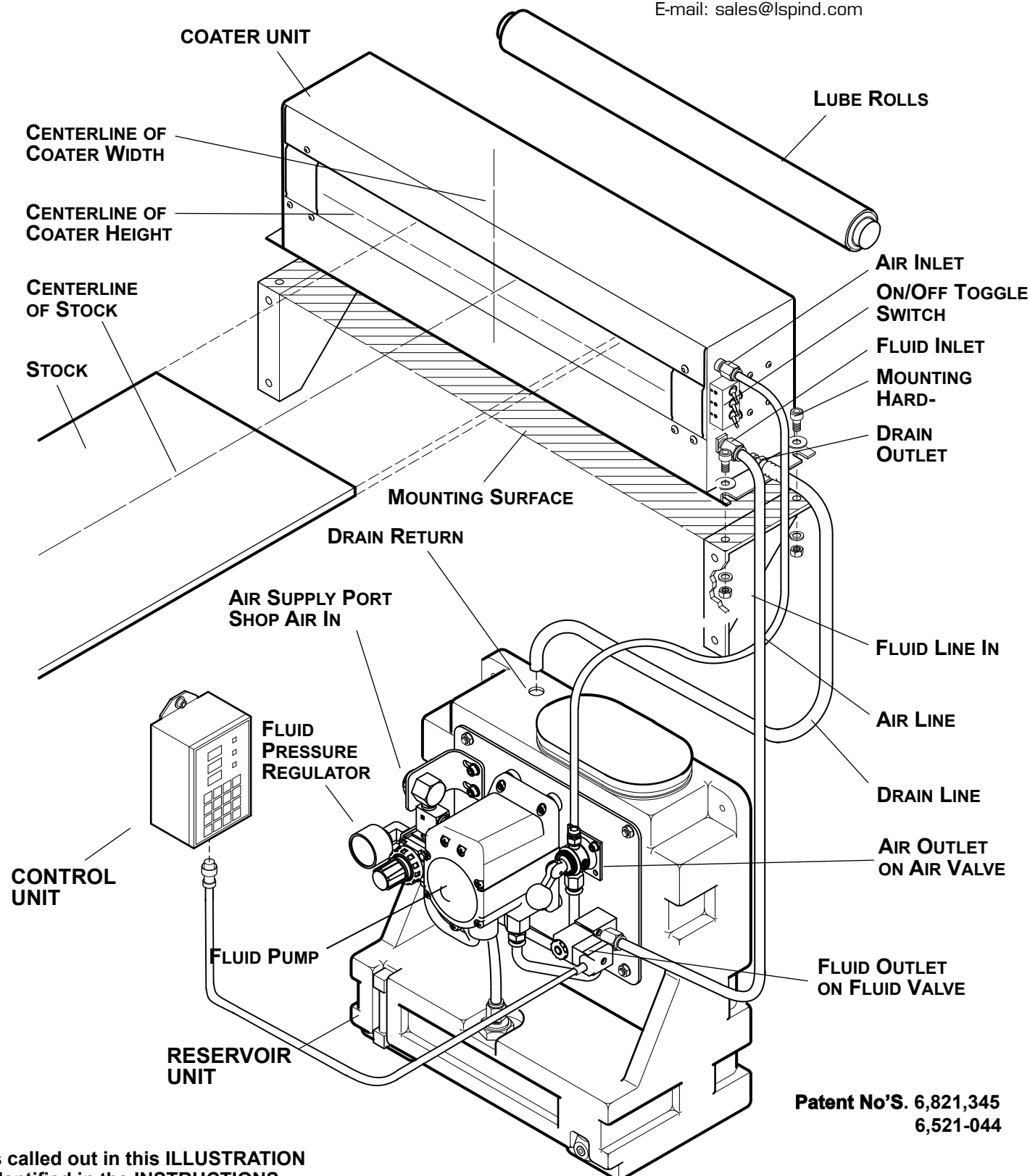

Patent No'S. 6,821,345  
6,521-044

Items called out in this ILLUSTRATION are identified in the INSTRUCTIONS by ALL CAPITAL LETTERS

12/10/13

# INSTALLATION INSTRUCTIONS

## A. Locating the COATER UNIT

The **COATER UNIT** is to be located so the **STOCK** to be coated will pass through the centers (both width and height) of its opening. The **COATER UNIT** must be oriented so the **STOCK** enters its front side (that side labeled with instructions and logo).

Good results can be had with the **STOCK** somewhat off-center in this opening. However, the closer the centering, the better will be performance. Very narrow and thick stock will require closer centering in the width of the **COATER** for an even coating. The **LUBE ROLLS** float up/down, so the **STOCK** may be off-center in the height of the opening to limited degree.

To have a **MOUNTING SURFACE** on which the **COATER** can be placed at the proper height usually requires some fabrication. This **SURFACE**, and any bracketing used, must give solid support. The **SURFACE** need not be one continuous flat, but may be two separate pads. This **SURFACE (SURFACES)** should be in one plane, and be as parallel to the **STOCK** to be lubricated as practical.

## B. Mounting the COATER UNIT

The **COATER UNIT** is mounted by having its feet bolted to the **MOUNTING SURFACE**. Use 1/2" bolts with heavy flat washers to do this. If the **SURFACE** is more than 3/8" thick, you may drill and tap for 1/2" thread and bolt into it. If this **SURFACE** is 3/8" or less, drill 9/16" holes through it and use a nut and lock washer on the underside.

## C. Locating the RESERVOIR UNIT

The **RESERVOIR UNIT** may be set in place on its feet, or mounted on a wall using the holes provided. When deciding on a location for this **UNIT**, consider the following:

1. The lubricant tank will require filling. Make sure its location will allow this to be done without hinderance and encumbrance.
2. **AIR/FLUID/DRAIN LINES** will need to be routed to the **COATER UNIT** and attached (see para. D below). Make sure these lines are long enough to reach from this **UNIT** to the **COATER**. Longer **LINES** are available if needed.
3. An **AIR SUPPLY** will need to be connected to the **RESERVOIR UNIT** (see para. E below). Make sure the location of this **UNIT** allows this done without difficulty.
4. Make sure the routing of any of the **LINES** above will not cross passage ways, will not ensnare, and will not interfere with operations.

**NOTE:** **RESERVOIR UNITS** are available in various capacities. Make sure you can identify the **UNIT** you are installing should you need to use the **REPLACE-MENT PARTS** listing later.

## D. Attaching the Air/Fluid/Drain Lines

An **AIR LINE**, **FLUID LINE**, AND **DRAIN LINE** will need to be routed between the **RESERVOIR** and **COATER UNITS**, and have their respective connections made. If these **LINES** are too long, they may be cut to appropriate lengths; however, always leave enough slack to prevent sharp bends that might cause the **LINES** to kink. Using the front illustration as example, make the following connections:

1. Connect the 1/4" O.D. **AIR LINE** at the **AIR INLET** on the **COATER UNIT**, and at the **AIR OUTLET** on the **RESERVOIR UNIT**.
2. Connect the 1/4" O.D. **FLUID LINE** at the **FLUID INLET** on the **COATER UNIT**, and at the **FLUID OUTLET** on the **RESERVOIR UNIT**.
3. Connect one end of the 5/8" O.D. **DRAIN LINE** to the **DRAIN OUTLET** on the **COATER UNIT**, and insert the other end into the **DRAIN RETURN** hole in the top of the **RESERVOIR UNIT**.

**NOTE:** Use a thread sealant on all the pipe connections to insure against air and fluid leakage.

## E. Attaching the Air Supply

Connect an **AIR SUPPLY** of at least 70 P.S.I. at the **AIR SUPPLY PORT** on the **RESERVOIR UNIT**. It is advised that you make this connection with a quick-disconnect fitting to allow shutting down the **UNIT** should an **AIR OR FLUID LINE** to the **COATER** become loose or severed. For the best performance, it is also advised that this **AIR SUPPLY** be filtered, regulated, and lubricated.

## F. Installing the LUBE ROLLS

The **LUBE ROLLS** are shipped separately to prevent damage to their support bearings. There is no distinction between the two **ROLLS** (they are identical). Install the **ROLLS** as described below and shown in Figure #1.

1. Open the **ROLL CARRIAGES** using the **AIR VALVE** found on the **RESERVOIR UNIT** for this purpose.
2. Install the lower **LUBE ROLL** by simply setting it in its place. Make sure it is centered and resting level on its support bearings.
3. **WARNING** - Before installing the upper **LUBE ROLL SET SCREWS, (28) AND JAM NUT, (27) MUST BE REMOVED** to allow **ROLL** to be installed. These **Jam Nuts** and **Set Screws** hold the **SPRING LOADED RETAINERS** in place.
3. Install the upper **LUBE ROLL** by forcing it upwards past its spring loaded retainers until it snaps into place. Before applying force, make sure the **ROLL** is centered and is in contact with its support bearings at both ends.
4. Insert **SET SCREWS, (28)**, at both ends until they gently touch the **SPRING LOADED RETAINERS**.
5. Apply the **JAM NUTS, (27)**, to the **SET SCREW, (28)**, and lock in place.
4. Close **ROLL CARRIAGES** using the **AIR VALVE**.

## G. Installing the CONTROL UNIT

Various methods may be used to control the dispensing of the lubricant applied. If using an **L.S.P. CONTROLLER**, see the **INSTRUCTIONS** supplied with it for installation. If using the P.L.C. (Program Logic Control) on your machine, see para. E. under **OPERATING INSTRUCTIONS** for directions.

# PARTS for the RESERVOIR UNIT

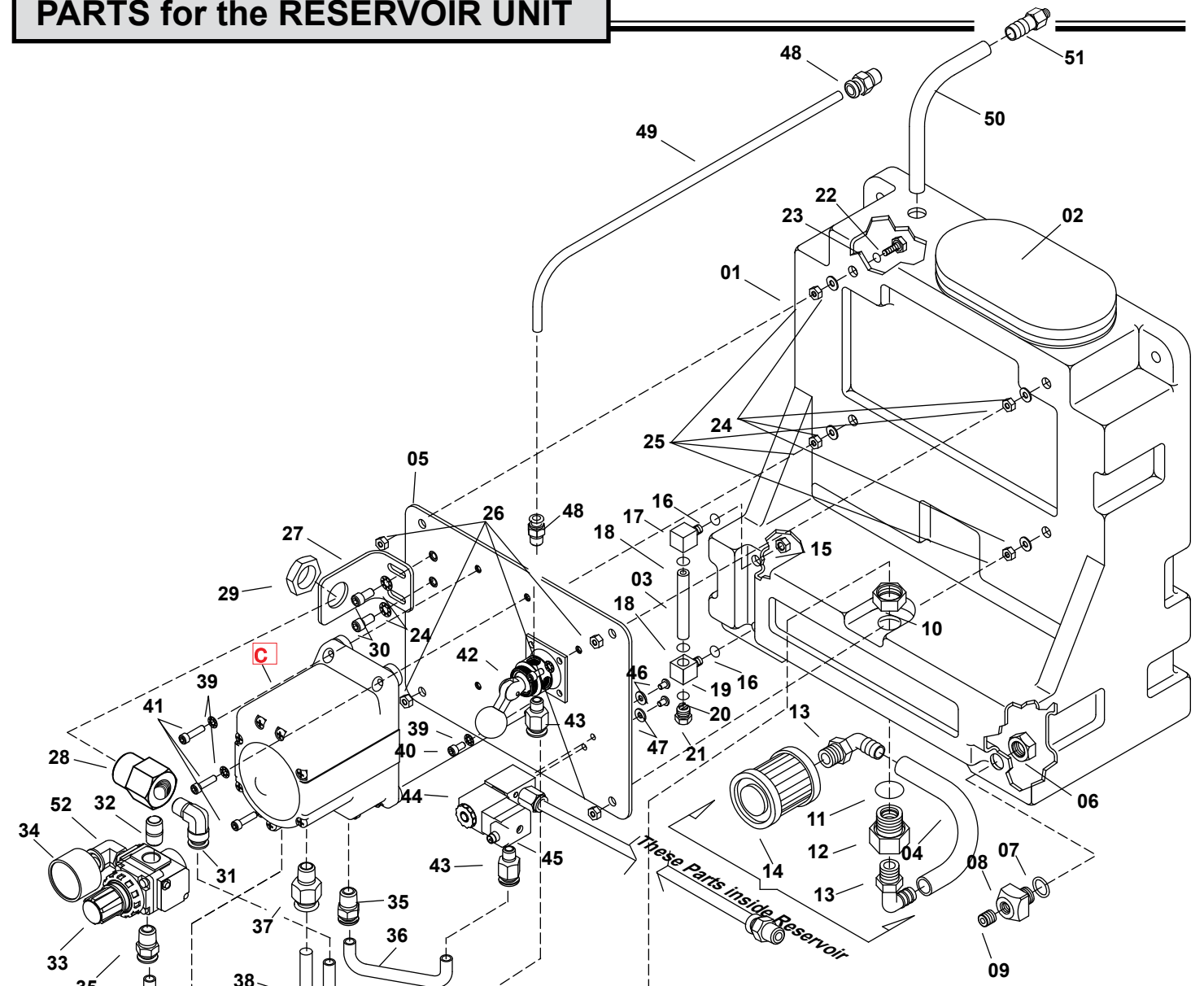

## RESERVOIR UNIT PARTS

Key No.	Part Number	Qty Used	Part Name or Description of Item
<b>Following parts are specific to the 4 Gallon Reservoir only</b>			
01	RES036	1	RESERVOIR, Fluid: 4 gallon
02	COV019	1	COVER, Lid: 4 gallon tank
03	PIP008	1	PIPE, Plastic: sight gage 4 gallon
04	TUB162	1	TUBE, Plastic: outlet 4 gallon
05	PLT098	1	PLATE, Mounting: pump
<b>Following parts are specific to the 8 Gallon Reservoir only</b>			
01	RES037	1	RESERVIOR, Fluid: 8 gallon
02	COV020	1	COVER, Lid: 8 gallon tank
03	PIP009	1	PIPE, Plastic: sight gage 8 gallon
04	TUB160	1	TUBE, Plastic: outlet 8 gallon
05	PLT099	1	PLATE, Mounting: pump
<b>Following parts are specific to the 15 Gallon Reservoir only</b>			
01	RES038	1	RESERVOIR, Fluid: 15 gallon
02	MLD002	1	COVER, Lid: 15 gallon tank
03	PIP010	1	PIPE, Plastic: sight gage 15 gallon
04	TUB156	1	TUBE, Plastic: outlet 15 gallon
05	PLT099	1	PLATE, Mounting: pump

See next page for remainder of this Parts Listing

### NOTE

See **Operating Instructions, Parts List & Trouble Shooting for LSP Transfer Pump** in the **FC-7310 Operating Instructions, Parts List & Trouble Shooting**. See call-out C

# PARTS for the HEAD CARRIAGE

# OPERATING INSTRUCTIONS

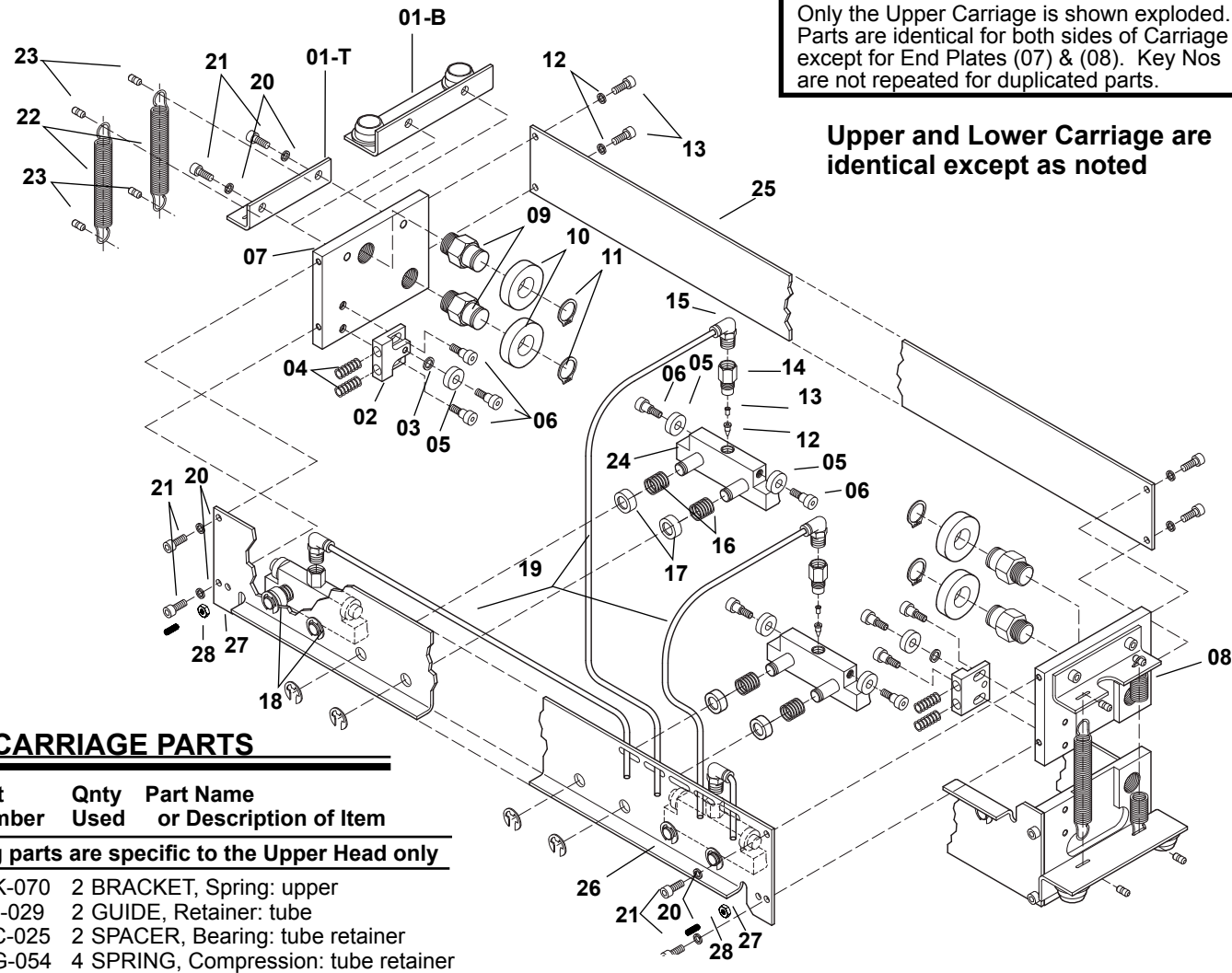

**NOTE:**  
Only the Upper Carriage is shown exploded. Parts are identical for both sides of Carriage except for End Plates (07) & (08). Key Nos are not repeated for duplicated parts.

Upper and Lower Carriage are identical except as noted

Lower Carriage shown assembled, and how it attaches to the Upper Carriage with Extension Springs.

## HEAD CARRIAGE PARTS

Key Part Qnty Part Name  
No. Number Used or Description of Item

**Following parts are specific to the Upper Head only**

01-T	BRK-070	2	BRACKET, Spring: upper
02	GID-029	2	GUIDE, Retainer: tube
03	SPC-025	2	SPACER, Bearing: tube retainer
04	SPG-054	4	SPRING, Compression: tube retainer
05	BRG-006	2	BEARING, Ball: retainer
06	SCR-179	6	SCREW, Shoulder: 1/2" dia x 3/8" lg

**Following parts are specific to the Lower Head only**

01-B	BRK-071	2	BRACKET, Spring: lower
------	---------	---	------------------------

**Following parts are common to both Coaters and Heads**

07	PLT-095	2	PLATE, Head: right side
08	PLT096	2	PLATE, Head: left side
09	AXL-003	8	AXIAL, Bearing: roll support
10	BRG-005	8	BEARING, Ball: roll support
11	RGR-030	8	RING, Retaining: std external
20	WAS-022	24	WASHER, Lock: 5/16 hi-collar
21	SCR-100	24	SCREW, Cap: 5/16 UNF x 3/4" lg
22	SPG-052	4	SPRING, Extension: head
23	PIN-007	8	PIN, Retainer: spring
27	NUT-065	2	NUT, Jam, 8-36
28	SCR-111	2	SCREW: Set, cup point, 8-36

Qty Used for the following is the number required for each OUTLET, Dispenser: (Key # 24) used in the given Coater

05	BRG-006	2	BEARING, Ball: dispenser
06	SCR-179	2	SCREW, Shoulder: 1/2" dia x 3/8" lg
12	CHK-016	1	CHECK, Fluid: dispenser
3	EYE-006	1	EYELET, Check: dispenser
14	INL-045	1	INLET, Fluid: dispenser
15	FIT-102	1	FITTING, Elbow: 5/32" tube x 1/8 NPT
16	SPG-055	2	SPRING, Compression: dispenser
17	SPC-026	2	SPACER, Spring: dispenser
18	RGR-031	2	RING, Retaining: E type
19	BLK-013	A/R	TUBING, Plastic: 5/32" O.D.

**Differences between Upper and Lower Carriage**  
Upper Carriage uses Upper Bracket at (01), and uses Roll Retainer parts (02) thru (06)  
Lower Carriage uses Lower Bracket at (01), and has no Roll Retainer.

Key Part Qnty Part Name  
No. Number Used or Description of Item

**Following parts are specific to the 60" Coater only**

24	440OUT01	7	OUTLET, Dispenser: 60" head
25	PLT091	1	PLATE, Back: 60" head
26	PLT093	1	PLATE, Front: 60" head

**Following parts are specific to the 72" Coater only**

24	440OUT02	7	OUTLET, Dispenser: 72" head
25	PLT092	1	PLATE, Back: 72" head
26	PLT094	1	PLATE, Front: 72" head

## A. Inserting the STOCK

At times, STOCK will have to be fed through the COATER UNIT and into the press. This is to be done as follows:

1. The ROLL CARRIAGE must be opened before feeding STOCK through the UNIT or there may be damage done to the LUBE ROLLS. This is done using the AIR VALVE on the RESERVOIR UNIT.
2. Once open, feed the STOCK through the UNIT.
3. Close the ROLL CARRIAGE with the AIR VALVE.

## B. Priming the Fluid System

At startup (or if the fluid tank is left to run dry) the FLUID LINE will contain only air. Before beginning (continuing) operation, these LINES should be filled (refilled) with lubricant. This is done by having the CONTROL UNIT cycle until the system is filled and lubricant is being applied at the LUBE ROLLS.

## C. Selecting the Area to be Lubricated

If lubricant is only required on a portion of the LUBE ROLL width, that area not needing lubricant can be left dry. This is done by using the two sets of PUSH BUTTONS located at the sides of the COATER UNIT. One set controls application to the upper LUBE ROLL, the other controls application to the lower LUBE ROLL.

The PUSH BUTTONS are ends of valve spools. Pulling a BUTTON in from the front side of the COATER allows lubricant to go to its respective area on the LUBE ROLL. Pushing the BUTTON in from the front side stops lubricant flow to that area. See Figure #2 for illustration.

These BUTTONS, control the lube to respective areas on the LUBE ROLL. The labels on the Valve Manifold aid in making your selection.

## D. Removing the LUBE ROLLS

Use the following instructions and Fig. #1 for direction.

1. Open ROLL CARRIAGE using the 3-Way AIR VALVE.
2. Remove STOCK from COATER UNIT.
3. Lift out the lower LUBE ROLL. This ROLL is removed by simply lifting it out of its ROLL CARRIAGE.
4. **WARNING**, The top ROLL is held in place with SPRING LOADED RETAINERS plus a SET SCREW (28) and JAM NUT (27) at both ends. Loosen the JAM NUTS at both ends and completely remove the SET SCREWS, so that the SPRING LOADED RETAINERS are unlocked and unrestricted. Place a screw driver shank under the cover and on top of the roll at one end. Wedge the handle up so that the shank forces the roll down, dislodging it from its spring loaded retainers. If possible offer some support to the roll so that it does not fall down with force and damage the bottom bearings.
5. See para. F. under INSTALLATION INSTRUCTIONS for re-installing the ROLLS.

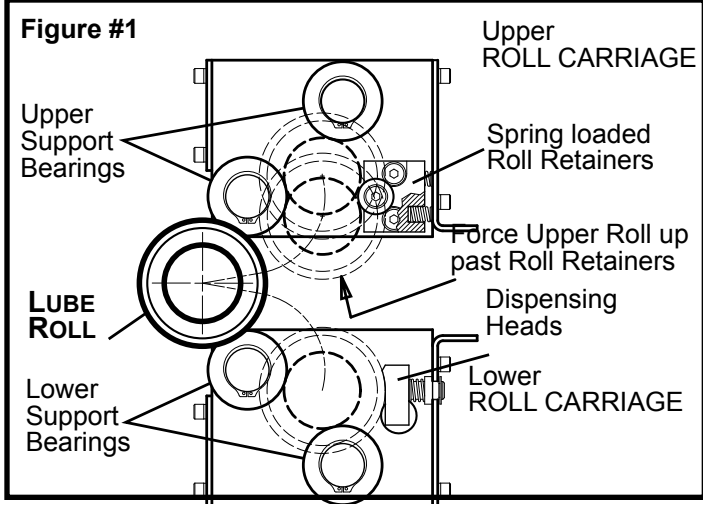
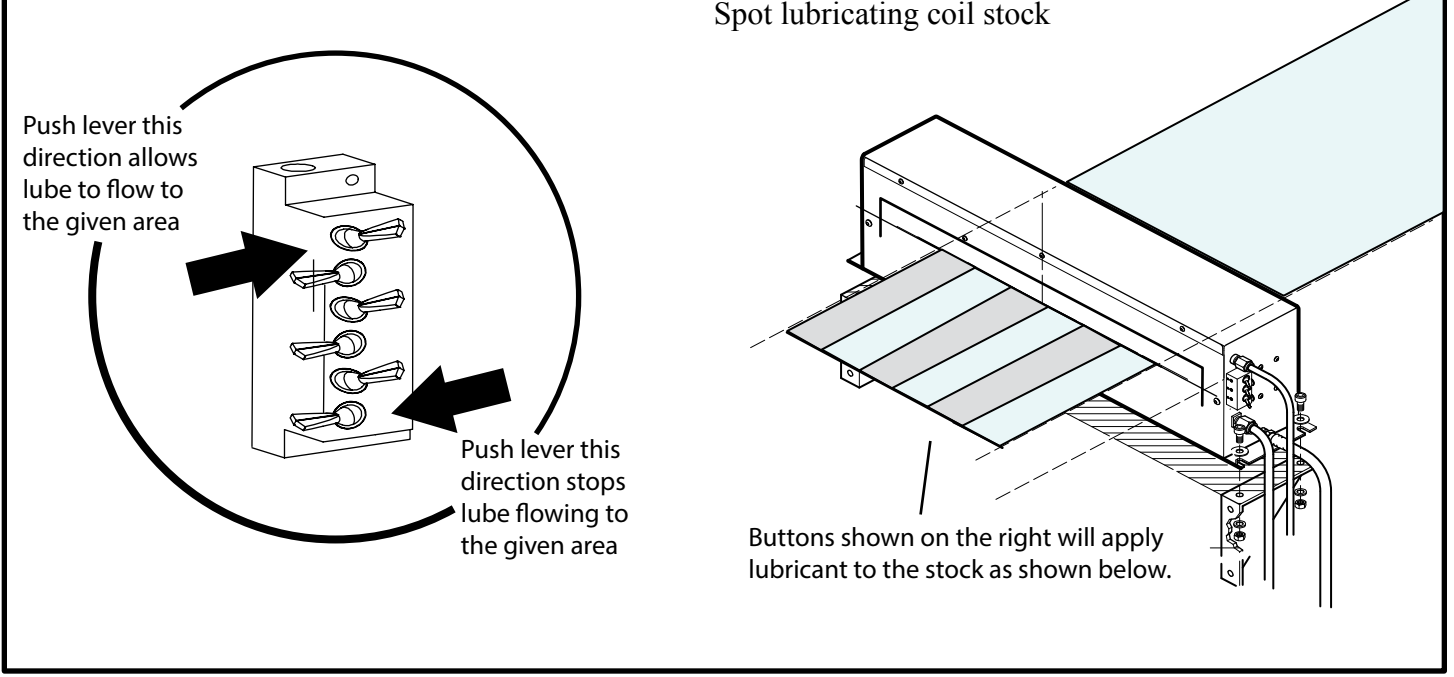

Figure #2



OPERATING INSTRUCTIONS (continued)

**E. Using the CONTROL UNIT**

The **CONTROL UNIT** governs dispensing the lubricant by controlling the **FLUID VALVE** on the **RESERVOIR UNIT**. The lubricant in the **RESERVOIR UNIT** is pressurized by the **FLUID PUMP** and is held in check by the **FLUID VALVE**. When activated (opened) by the **CONTROL UNIT**, the **FLUID VALVE** allows the lubricant to flow to the dispensing heads and wet the **LUBE ROLLS**. This is done as the **STOCK** is being fed out. As the feed-out drives the wetted **ROLLS**, the lubricant is deposited onto the **STOCK**.

Any device that can be programmed to provide the proper functions may be used as the **CONTROL UNIT**. It might be a **UNIT** supplied by **L.S.P.** or other source, or the controller (P.L.C.) on your machine if one is provided.

The basic functions to be programmed are a Trigger-Point and an On-Time. The Trigger-Point being set to begin the On-Time (usually at the beginning of stock feed-out). On-Time being set for that amount of time the **FLUID VALVE** is to be activated to dispense lubricant (usually for the duration of the feed-out).

To enhance performance or adapt to special situations, other functions may be desired of the **CONTROL UNIT**. **For example:** With very long feed-outs (or roll forming) applying the lubricant in a series of short pulses will allow more control of the application. With very short feed-outs applying a pulse of lubricant every third, fifth, or tenth stroke may be best. If you think your application might require some extended functions, call **L.S.P.** or our representative for advice.

**F. Using the FLUID PRESSURE REGULATOR**

The **FLUID PRESSURE REGULATOR** on the **RESERVOIR UNIT** sets the pressure at which the lube is supplied to the dispensing heads. Turning its knob counter-clockwise will reduce the amount of lubricant dispensed; clockwise will increase the amount. This control is usually adjusted during operation until the desired amount of lubricant coating is attained.

**HOW TO REPLACE THE FELT SLEEVES.**

The **FELT ROLLERS** consist of a metal tube with end caps and a **FELT SLEEVE**. The metal tube and end caps will need to be replaced infrequently whereas the **FELT SLEEVE** will see a periodic replacement due to wear.

1. Remove the **ROLLERS** from the **FloaterCOATER** by lifting out the bottom one and prying the top one loose.
2. Cut the **FELT SLEEVE** from the **ROLLER**.
3. Slide new **FELT SLEEVE** over the **ROLLER**.  
*The end caps protrude a little higher than the roll and may require a little extra effort to slide the Sleeve over the end cap piece.*
4. Soak in warm water until saturated then remove and allow to dry overnight.
5. Reassemble and **FLOATERCOATER** is ready for use.

**Warning:**

Always disconnect the air supply whenever the FloaterCoater has to be disassembled.

**COATER PARTS LISTING**

Key No.	Part Number	Qty Used	Part Name or Description of Item
<b>Following parts are specific to the 60" Coater</b>			
01		2	SELECT ROLLS FROM CATALOG
04	FRM-026	1	FRAME, Cover: 60"
27	BAS-029	1	BASE, Frame: 60"
<b>Following parts are specific to the 72" Coater</b>			
01		2	SELECT ROLLS FROM CATALOG
04	FRM-027	1	FRAME, Cover: 72"
27	BAS-030	1	BASE, Frame: 72"
<b>Following parts are common to both FloaterCoaters</b>			
02	WAS-103	4	WASHER, Retaining
03	RGR-041	4	RING, Retaining
05	GRD-022	4	GUARD, Shield
06	WAS-008	12	WASHER, Lock: # 8 internal tooth
07	SCR-089	6	SCREW, Button Hd: 8-32 X 1/4
08	FIT-035	1	FITTING, Nipple: short 1/8 NPT
09	FIT-103	1	FITTING, Adapter: 1/8 NPT X 1/4 OD
10	BHD-002	1	BULKHEAD, Block: fluid inlet
11	FIT-105	3	FITTING, Elbow: 1/4" tube x 1/8 NPT
12	PIS-030	2	PISTON, Air: upper lift
13	RGO-086	4	RING, Seal: "O" type
14	CYL-051	2	CYLINDER, Air: lift
15	PIS-031	2	PISTON, Air: lower lift
16	GID-030	2	GUIDE, Head
17	BRK-080	6	BRACKET, Tub: mounting
19	FIT-104	1	FITTING, Union Y type
20	WAS-001	7	WASHER, Lock: #10 internal tooth
21	SCR-098	2	SCREW, Button Hd: 10 - 32 X 1/2"
22	420-FIT-01	1	FITTING, ASSEMBLY, air inlet
23	SCR-102	4	SCREW, Button Head
25	SPG048	4	SPRING, Compression
26	SCR-099	8	SCREW, Button Hd: 5/16 - 24 X 1/2"
28	WAS-028	4	WASHER
30	HSG-243	2	HOUSING, Valve: 7-Port
31	VAL-015	14	VALVE, On/Off
32	SCR-141	14	SCREW, Set: 8 - 32 X 1/2
33	FIT-102	14	FITTING, Elbow: 5/32" tube X 1/8 NPT
34	FIT-003	2	FITTING, Plug: 1/8 NPT

**Following parts are tubing, NOT SHOWN**  
 BLK001 - TUBING, Air, Plastic: 1/4 O.D. (NOT SHOWN)  
 BLK013 - TUBING, Fluid, Plastic: 5/32 O.D. (NOT SHOWN)

**NOTE**  
 See **PARTS for CARRIAGE HEADS** on page 6 for an illustration and parts list for items keyed "A" and "B"

**PARTS for the COATER UNIT**

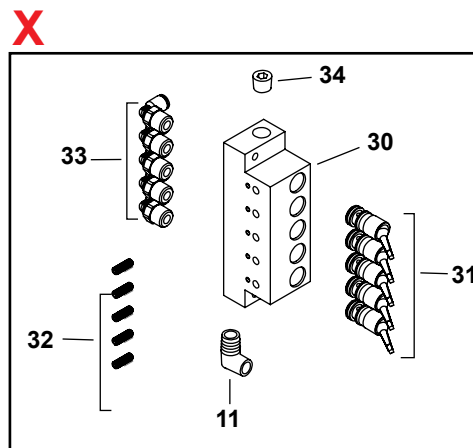
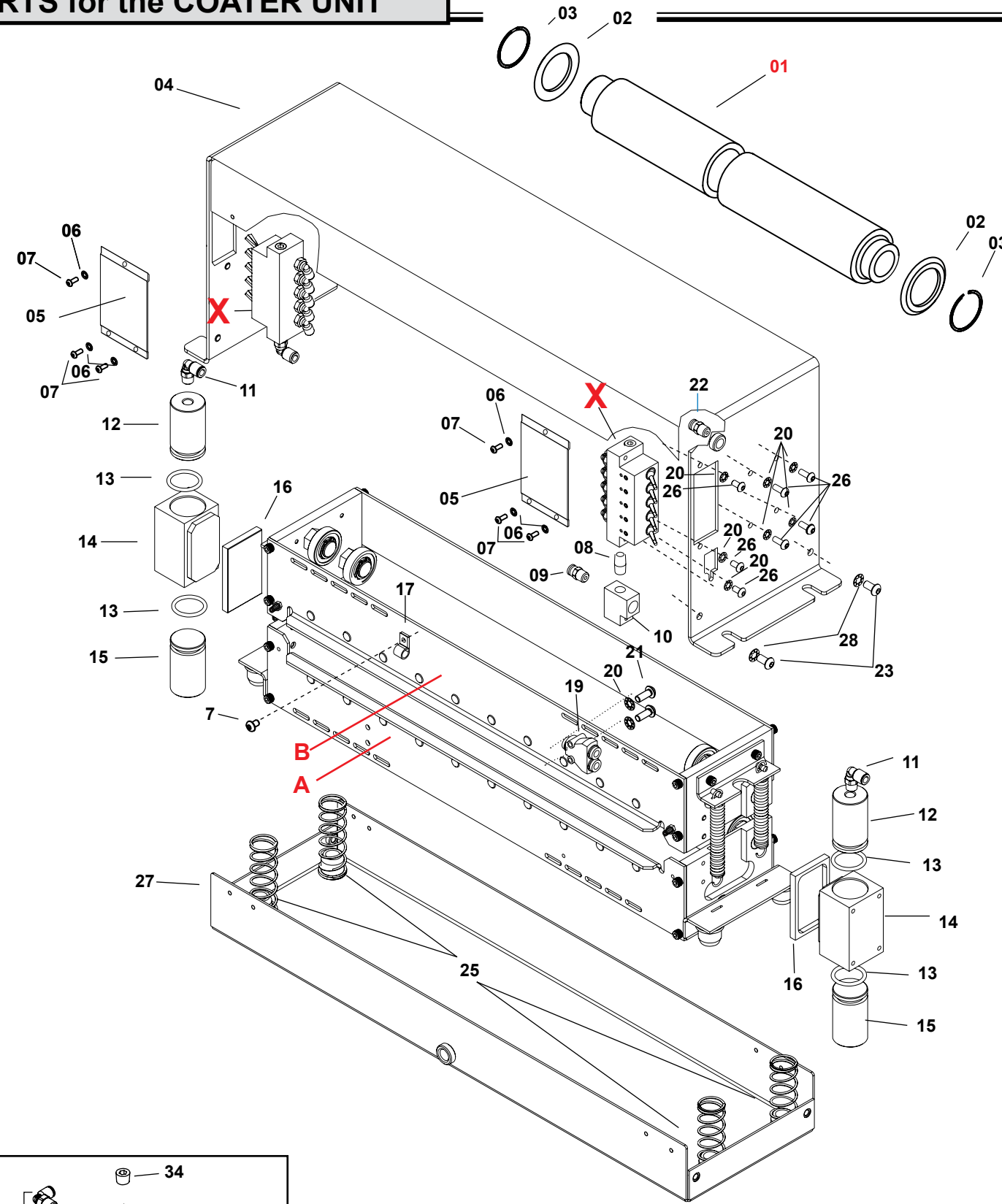

**NOTE**  
 See **PARTS for CARRIAGE HEADS** on page 6 for an illustration and parts list for items keyed "A" and "B"