

INSTALLATION, OPERATION, and TROUBLESHOOTING

with REPLACEMENT PARTS LISTING for
 MiniCoater Model Nos. **MC1001** replaces MC101,
MC1002 replaces MC103, **MC1003** replaces MC104,
MC1004 replaces MC-105 & **MC1005**



LSP[®]
 INDUSTRIES, INC.
 P.O.Box 5303, Rockford, IL • 61125
 5060-27th Ave, Rockford, IL • 61109
 Tel: 815-226-8090 • Fax: 815-226-9250
 E-mail: sales@lspind.com

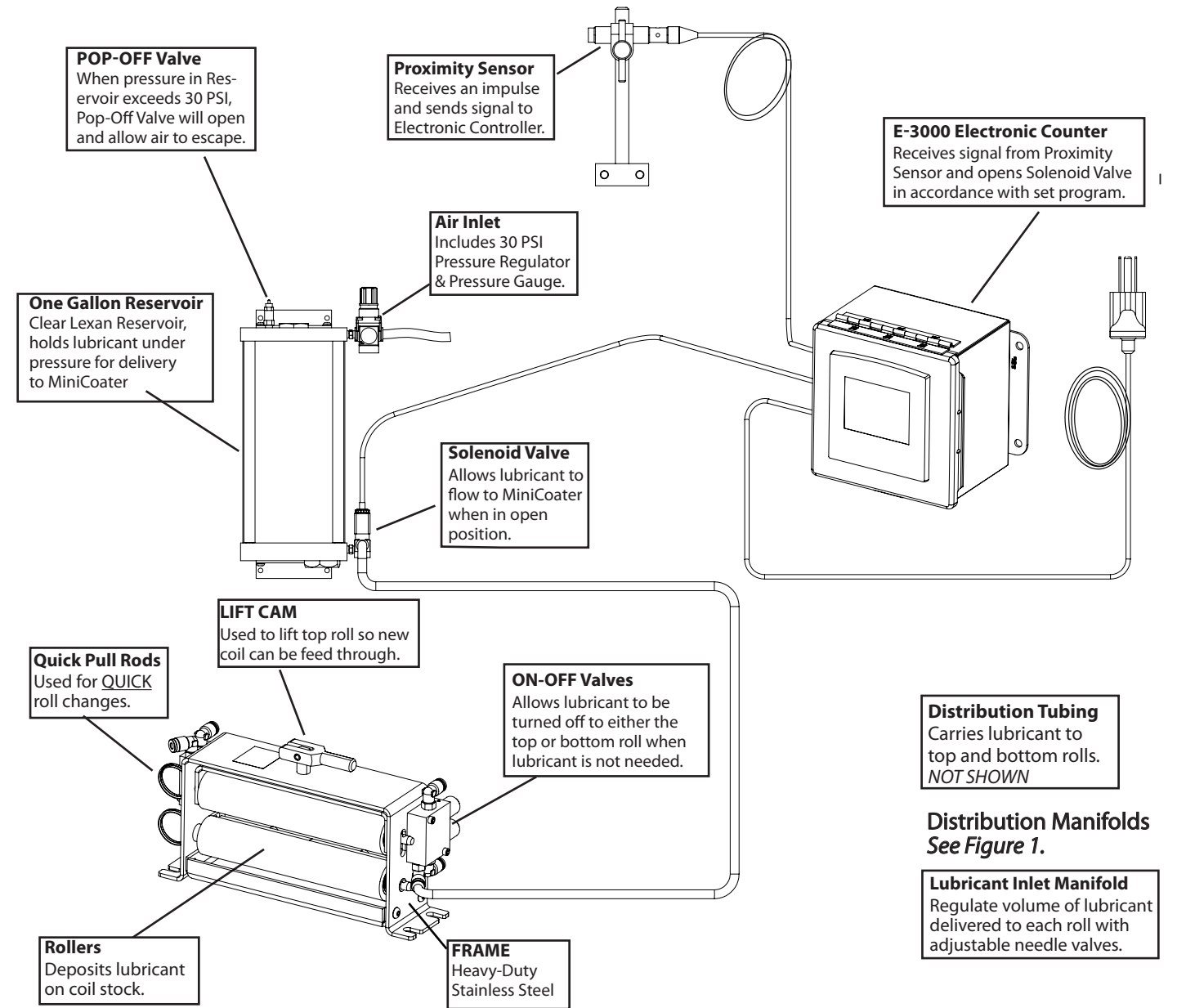
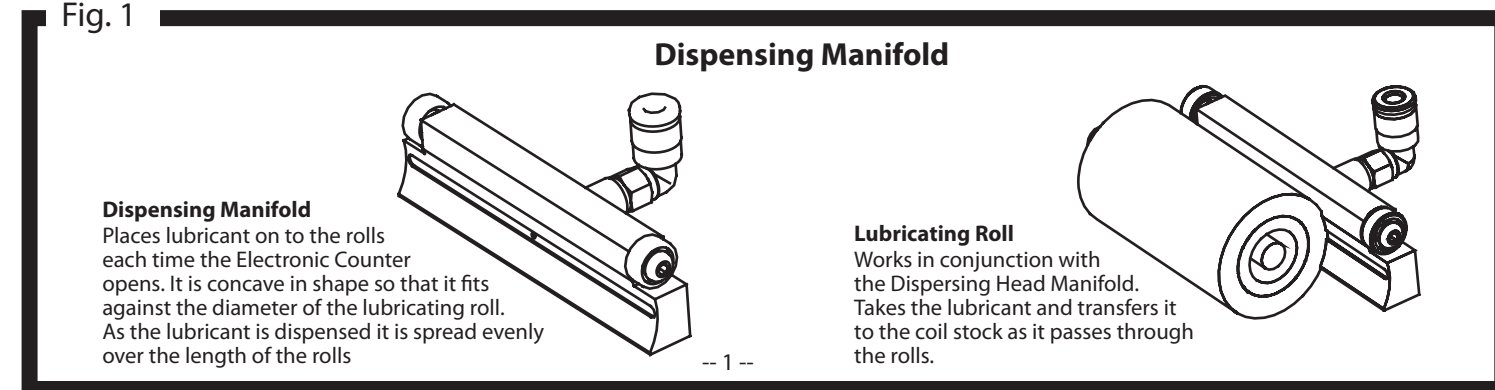

Fig. 1



INSTALLATION INSTRUCTIONS

A. Locating the MiniCoater.

The MiniCoater should be located so that the Coil STOCK will pass through the centers (both width and height) of its opening. The MiniCoater must be oriented so the Coil STOCK enters from the back side, the opposite side of the exposed Rollers.

The Coil STOCK should be on the same level as the top of the bottom Roller. Results are always best when the stock is centered in the width of the MiniCoater for an even coating.

To have a MOUNTING SURFACE on which the MiniCoater can be placed at the proper height may require some fabrication. This SURFACE, and any bracketing used, must give solid support. The SURFACE need not be one continuous flat, but may be two separate pads. This SURFACE (SURFACES) should be in one plane, and be as parallel to the STOCK to be lubricated as practical.

B. Mounting the MiniCoater

The MiniCoater is mounted by having its feet bolted to the MOUNTING SURFACE. Use 1/4" bolts with heavy flat washers to do this. If the SURFACE is 1/4" or more thick, you may drill and tap for 1/4" thread and bolt into it. If this SURFACE is less than 1/4", drill 9/32" holes through it and use a lock washer and nut on the underside.

C. Attaching an Over-Flow Tube

When first starting up a job the lubricant supply settings may be set too high and an over supply of lubricant may be sent to the MiniCoater. Attach the overflow tubing to the back side of a COLLECTION RESERVOIR and run it into any container to capture the overflow. Once the correct settings for the lubricant dispensing is correctly set there will be no overflowing of lubricant.

D. Locating the RESERVOIR UNIT

The RESERVOIR UNIT will be mounted on a wall or any vertical object. It can be mounted either higher or lower than the MiniCoater. When deciding on a location for this UNIT, consider the following:

1. The lubricant tank will require filling. Make sure its location will allow this to be done without hindrance and encumbrance.
2. FLUID TUBING will need to be routed to the MiniCoater and attached. The RESERVOIR comes with 6' of tubing. Longer TUBING is available from LSP If needed.
3. An AIR SUPPLY will need to be connected to the RESERVOIR UNIT (see para. F. below). Locate the RESERVOIR so this can be done without difficulty.

NOTE: The RESERVOIR is a pressure pot with a 20 PSI PRESSURE RELIEF VALVE. A PRESSURE REGULATOR and GAUGE is included with the RESERVOIR.

E. Attaching the FLUID LINE

CONNECT THE FLUID LINE between the RESERVOIR and MiniCoater, If the LINE is too long it may be cut to the appropriate length; however, always leave enough slack to prevent sharp bends that might cause the LINE to kink. Using the front illustration as example, make the following connections:

1. Connect a 1/4" OD FLUID LINE at the RESERVOIR UNIT OUTLET on the underside of the vessel.

2. Connect the other end of the 1/4" OD FLUID LINE to the LUBRICANT MANIFOLD located on the side of the MiniCoater.

NOTE: All Fittings are supplied, push/pull type fittings. Gently press the tubing into the fittings until they bottom out.

F. Attaching the AIR SUPPLY

Install the AIR REGULATOR and PRESSURE GAUGE to the AIR SUPPLY PORT ON the RESERVOIR Unit. ALWAYS USE AN AIR REGULATOR WITH A 30 PSI MAXIMUM OUTPUT. Connect an AIR SUPPLY of at least 30 PSI at the AIR REGULATOR in-port. It is advised that you make this connection with a quick-disconnect fitting to allow shutting down the Unit for refilling or should the AIR have to be shut down in an emergency.

F. LUBE ROLLS

The MiniCoater is shipped with the LUBE ROLLS already installed. LUBE ROLLS can be changed by removing the SNAP RINGS and then removing the LUBE ROLLS.

G. Installing the CONTROL UNIT

Various methods may be used to control the dispensing of the lubricant. If using an LSP CONTROLLER, see the INSTRUCTIONS supplied with it for installation. If using the PLC (PROGRAMMABLE LOGIC CONTROL) on your machine, see paragraph "D" under OPERATING INSTRUCTIONS for directions.

OPERATING INSTRUCTIONS

A. Inserting the STOCK

When, STOCK has to be fed through the MiniCoater and into the press It is to be done as follows:

1. The ROLLER RELEASE KNOB IS SPRING loaded in the down position.
2. Lift up and align cross-bar so that it slides through the slit in the FRAME.
3. Twist KNOB a quarter turn until KNOB can be released and the CROSS-BAR comes to rest on top of the FRAME.
4. The rolls are now open. Insert STOCK and turn the ROLLER RELEASE KNOB so that so CROSS-BAR slides back through the FRAME and the spring closes the top ROLLER on the Stock.

B. Priming the Fluid System

At startup (or if the fluid tank is left to run dry) the FLUID-LINE will contain only air. Before beginning (continuing) operation, these LINES should be filled (refilled) with lubricant. This is done by having the CONTROL UNIT cycle until the system is filled and lubricant is being applied at the LUBE ROLLS.

TROUBLESHOOTING INSTRUCTIONS

PROBLEMS	SOLUTIONS
I. No lubricant to any of the rolls.	A. Check to see if there is fluid in the reservoir. B. Check the Air Regulator Gauge to see if the air is on. C. Check the controller. 1. Hold hand on solenoid to feel actuation when controller receives a signal. If solenoid does not receive a signal. a. Solenoid may be bad b. Proximity switch may be misaligned or broken. c. Controller may be broken and not receiving or sending a signal.
II. The coil stock is coming out or the MiniCoater with dry stripes .	A. One of the manifolds is plugged . 1. Remove the tube from the manifold. 2. Remove the fitting from the manifold. 3. Blow air in the reverse direction that the lubricant flows. 4. Check and make sure that the hole is free and reassemble the lines.
III. Lubricant continues to flow in between cycles & in the rest mode.	A. Check the solenoid to see if it has to be replaced. B. Check the controller to see if it is broken and in the open position.
IV. Lubricant has become gummy in the MiniCoater.	A. Remove rolls, clean and purge the MiniCoater with water or solvent. B. Clean the rolls and reassemble the MiniCoater. This is caused when changing from oils or water solubles to synthetics. To avoid this problem, purge the system prior to filling with lubricants that are incompatible.
V. Not enough lubricant being dispersed onto the coil stock.	A. Is the controller set to stay open long enough to get a complete coating on each cycle of the feeder. B. Smooth rolls give the finest coating, A course roll will leave a much heavier coating.
VI. Too much lubricant being dispersed on the coil stock.	A. If large quantities of lubricant is being returned to reservoir, the open time on the controls is ope for too long a time. B, Try a smooth roll to reduce the amount of lubricant transferred to the coil stock.

Reservoir - One Gallon Lexan

Key	Part #	Qty	Description
01	VAL013	1	VALVE, Pop-Off
02	BRK107	2	BRACKET, Mounting
03	WAS002	4	WASHER, Lock
04	RGO091	1	RING, "O" Type: seal
05	SCR122	4	SCREW, Buton Head
06	PLG030	1	PLUG, Filler
07	SCR121	4	SCREW, Socket Head
08	ROD026	4	ROD, Tie
09	PLT111	1	PLATE, Top
10	FIT007	2	FITTING, Nipple
11	REG020	1	REGULATOR, Air
12	RGB033	2	BACKUP, Ring
13	RES043	1	RESERVOIR, Fluid
14	FIL005	1	FILTER, Fluid
15	RGO090	1	RING, "O" Type: seal
16	SCR120	4	SCREW, Socket Head
17	PLT121	1	PLATE, Bottom
18	420VAL02	1	VALVE, Solenoid
19	PLG034	1	PLUG, Drain
20	RGO062	1	RING, "O" Type
21	FIT058	1	FITTING, Drain

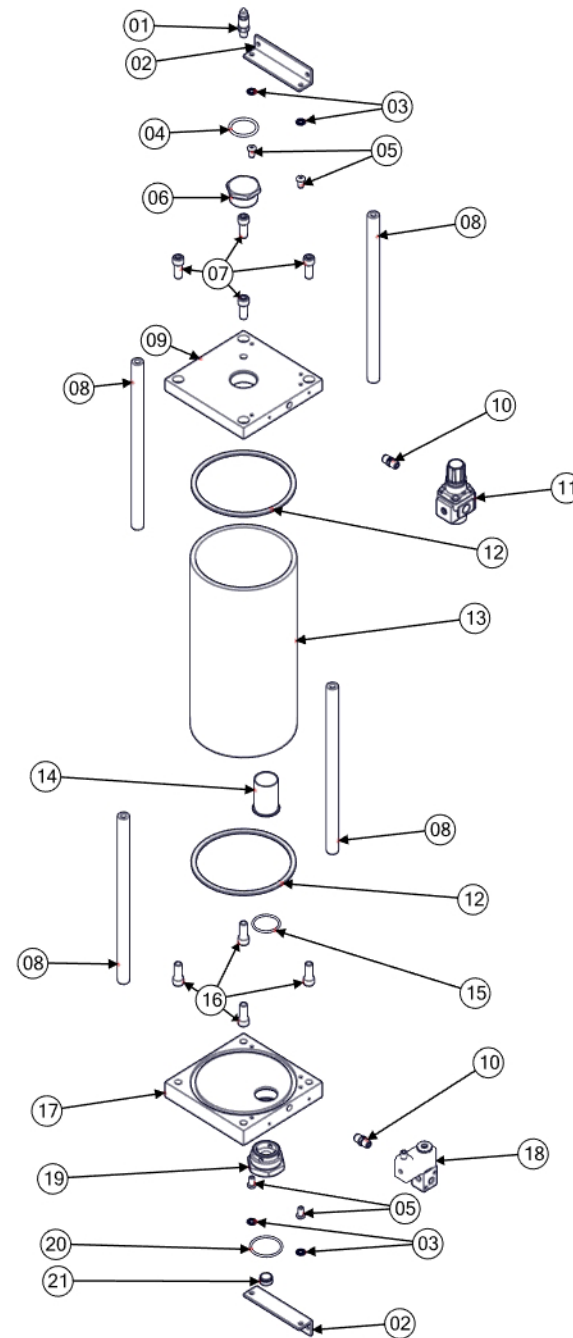

C. Selecting the Area to be Lubricated

Each roll in a MiniCoater contains one or more DISPERSION MANIFOLDS to dispense and spread the lubricant over the roll. Each DISPERSION MANIFOLD can be set to either be ON or OFF or to be adjusted to deliver more or less lubricant than other DISPENSER MANIFOLDS in its system. Due to their small sizes the MC-101 and the MC-103 each have two DISPERSION MANIFOLDS, one for the top and one for the for the bottom. The MC-106 has four DISPERSION MANIFOLDS, two top and two bottom and the MC-109 has six DISPERSION MANIFOLDS three top and three bottom. By adjusting the NEEDLE VALVES on the LUBRICANT MANIFOLD lubricant, volume will be controlled to either the top or the bottom DISPERSION MANIFOLD.

D. Using the CONTROL UNIT

The CONTROL UNIT governs dispensing the lubricant by controlling the FLUID VALVE on the RESERVOIR Unit. The lubricant in the RESERVOIR UNIT is kept under low pressure by shop air and is held in check by the SOLENOID VALVE. When activated (opened) by the CONTROL UNIT, the FLUID VALVE allows the lubricant to flow to the dispensing heads and wet the LUBE ROLLS. This is done as the STOCK is being fed out. As the feed-out drives the wetted ROLLS, the lubricant is deposited onto the STOCK. Any device that can be programmed to provide the proper functions may be used as the CONTROL UNIT. It might be a UNIT supplied by LSP or the controller (PLC) on the machine if one is provided.

The basic functions to be programmed are a Trigger-Point and an On-Time. The Trigger-Point being set to begin the On-Time (usually at the beginning of stock feed-out). On-Time being set for that amount of time the FLUID VALVE is to be open to dispense lubricant (usually for the duration of the feed-out).

To enhance performance or adapt to special situations, other functions may be desired of the CONTROL UNIT. For example: With very long feed-outs (or roll forming) applying the lubricant in a series of short pulses will allow more control of the application. With very short feed-outs applying a pulse of lubricant every third, fifth, or tenth stroke may be best. If you think your application might require some extended functions, call LSP or our representative for advice.

E. Using the FLUID PRESSURE REGULATOR

The FLUID PRESSURE REGULATOR on the RESERVOIR UNIT sets the pressure at which the lube is supplied to the dispensing heads. Turning its Knob counter-clockwise will reduce the amount of lubricant dispensed; clockwise will increase the amount. This control is usually adjusted during operation until the desired amount of lubricant coating is attained.

MAINTENANCE

F. Replacing Worn FELT ROLLS

The FELT ROLLERS consist of a metal tube with bearings and a FELT SLEEVE. The metal tube and bearings will need to be replaced very infrequently whereas the FELT SLEEVE will see a periodic replacement due to wear. Replacing the FELT SLEEVE is an easy item to replace.

1. Remove the FELT ROLLER from the MINICOATER by undoing the SNAP RING at one end of the frame and pulling the axle out the other side allowing the FELT ROLLER to fall free.
2. Cut FELT SLEEVE off of the ROLLER.
3. Slide new FELT SLEEVE onto the ROLLER.
4. Soak in warm water until saturated then remove and allow to dry overnight.
5. Reassemble and MINICOATER is ready for use.

PARTS for the MiniCoater UNITS

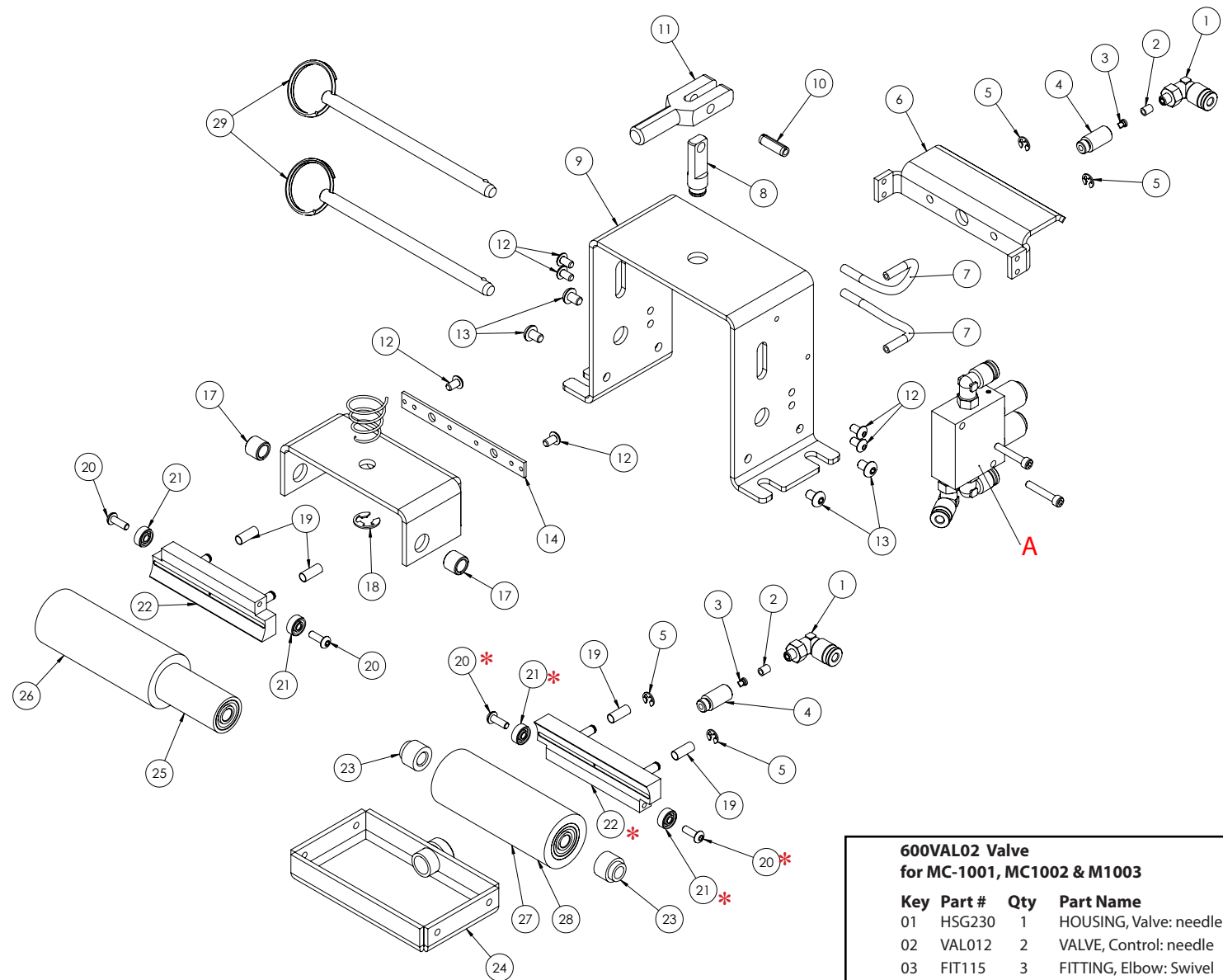

Numbers with Red Asterisks when Assembled
Comprise an Assembled Dispensing Head.

MiniCoater	Dispensing Head	Number of Dispensing Heads/Unit
MC1001	600OUT04	2
MC1002	600OUT05	2
MC1003	600OUT05	4
MC1004	600OUT05	6
MC1005	600OUT07	6

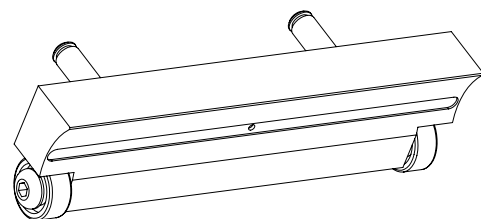

600VAL02 Valve for MC-1001, MC1002 & M1003

Key	Part #	Qty	Part Name
01	HSG230	1	HOUSING, Valve: needle
02	VAL012	2	VALVE, Control: needle
03	FIT115	3	FITTING, Elbow: Swivel
04	SCR117	2	SCREW, Button hd
05	SCR118	2	SCREW, Set: cup pt.

600VAL04 VALVE MC1004 & MC1005

Key	Part #	Qty	Part Name
01	HSG239	2	HOUSING, Valve: needle
02	VAL012	3	VALVE, Control: needle
03	FIT115	3	FITTING, Elbow: Swivel
04	SCR117	3	SCREW, Button hd
05	SCR118	3	SCREW, Set: cup pt.

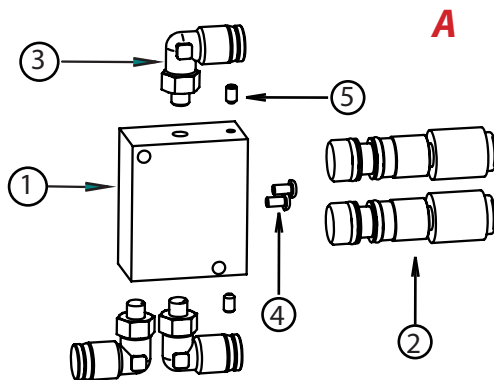

MiniCoater PARTS LISTING

MC1001, MC1002, MC1003, MC1004, MC1005

MC-1001 Parts List - 1 inch MiniCoater

Key	Part #	Qty	Part Name
01	FIT115	2	FITTING, Elbow: swivel
02	SPC029	2	SPACER, Duck Bill: check
03	CHK017	2	CHECK, Fluid: duck bill
04	INL046	2	INLET, Fitting: dispenser
05	RGR011	4	RING, Retaining
06	GRD011	1	GUARD, Protective
07	BLK015	2	TUBE, Specify length
08	PIN017	1	PIN, Lift: Upper head
09	FRM011	1	FRAME, Housing: 1 inch
10	PIN016	1	PIN, Spring:: 3/16
11	CAM003	1	CAM, Lift: upper
12	SCR131	6	SCREW, Button Head
13			NOT USED ON THIS ASSEMBLY
14			NOT USED ON THIS ASSEMBLY
15	SPG057	2	SPRING, Compression
16	BRK115	1	BRACKET, Assy: 1"
17	SPC033	2	SPACER, Bearing
18	RGR043	1	RING, Retaining
19	SPG056	4	SPRING, Compression
*20	SCR115	4	SCREW, Button Head
*21	BRG007	4	BEARING, Ball
22	600OUT04	2	OUTLET, Fluid: 1"
*23	SPC030	2	SPACER, Roll
24	RES051	1	RESERVOIR, fluid
A	600VAL02	1	VALVE, Needle
25	600TUB01	2	TUBE, Lubrication: 1"
26	SLV200	2	SLEEVE, Felt: 1"
27	600TUB11	2	TUBE, Smooth: 1" urethane
28	600TUB21	2	TUBE, Textured: 1" urethane
29	PIN018	2	PIN, Rod: quick release

MC-1002 Parts List - 3 inch MiniCoater

Key	Part #	Qty	Part Name
01	FIT115	2	FITTING, Elbow: swivel
02	SPC029	2	SPACER, Duck Bill: check
03	CHK017	2	CHECK, Fluid: duck bill
04	INL046	2	INLET, Fitting: dispenser
05	RGR011	4	RING, Retaining
06	GRD013	1	GUARD, Protective
07	BLK015	2	TUBE, Specify length
08	PIN017	1	PIN, Lift: Upper head
09	FRM013	1	FRAME, Housing: 3 inch
10	PIN016	1	PIN, Spring:: 3/16
11	CAM003	1	CAM, Lift: upper
12	SCR131	4	SCREW, Button Head
13	SCR089	4	SCREW, Button Head
14			NOT USED ON THIS ASSEMBLY
15	SPG057	2	SPRING, Compression
16	BRK116	1	BRACKET, Assy: 3"
17	SPC033	2	SPACER, Bearing
18	RGR043	1	RING, Retaining
19	SPG056	4	SPRING, Compression
20	SCR115	4	SCREW, Button Head
*21	BRG007	4	BEARING, Ball
*22	600OUT05	2	OUTLET, Fluid: 3"
*23	SPC030	2	SPACER, Roll
*24	RES052	1	RESERVOIR, fluid
A	600VAL02	1	VALVE, Needle
25	600TUB02	2	TUBE, Lubrication: 3"
26	SLV201	2	SLEEVE, Felt: 3"
27	600TUB12	2	TUBE, Smooth: 3" urethane
28	600TUB22	2	TUBE, Textured: 3" urethane
29	PIN019	2	PIN, Rod: quick release

MC-1003 Parts List - 6 inch MiniCoater

Key	Part #	Qty	Part Name
01	FIT115	4	FITTING, Elbow: swivel
02	SPC029	4	SPACER, Duck Bill: check
03	CHK017	4	CHECK, Fluid: duck bill
04	INL046	4	INLET, Fitting: dispenser
05	RGR011	8	RING, Retaining
06	GRD016	1	GUARD, Protective
07	BLK015	4	TUBE, Specify length
08	PIN017	1	PIN, Lift: Upper head
09	FRM016	1	FRAME, Housing: 6 inch
10	PIN016	1	PIN, Spring: 3/16
11	ROD024	2	ROD, Shaft: 6 inch
12	CAM003	1	CAM, Lift: upper
13	SCR089	6	SCREW, Button Head
14	PLT117	1	PLATE, Connector
15	SPG057	1	SPRING, Compression
16	BRK117	1	BRACKET, Assy: 6"
17	SPC033	2	SPACER, Bearing
18	RGR043	1	RING, Retaining
19	SPG056	8	SPRING, Compression
*20	SCR115	8	SCREW, Button Head
*21	BRG007	8	BEARING, Ball
*22	600OUT05	4	OUTLET, Fluid: 3"
*23	SPC030	2	SPACER, Roll
24	RES053	1	RESERVOIR, fluid
A	600VAL02	2	VALVE, Needle
25	600TUB03	2	TUBE, Lubrication: 6"
26	SLV202	2	SLEEVE, Felt: 6"
27	600TUB13	2	TUBE, Smooth: 6" urethane
27	600TUB23	1	TUBE, Textured: 6" urethane
29	PIN020	2	PIN, Rod: quick release

MC-1004 Parts List - 9 inch MiniCoater

Key	Part #	Qty	Part Name
01	FIT115	6	FITTING, Elbow: swivel
02	SPC029	6	SPACER, Duck Bill: check
03	CHK017	6	CHECK, Fluid: duck bill
04	INL046	6	INLET, Fitting: dispenser
05	RGR011	12	RING, Retaining
06	GRD019	1	GUARD, Protective
07	BLK015	6	TUBE, Specify length
08	PIN017	1	PIN, Lift: Upper head
09	FRM019	1	FRAME, Housing: 9 inch
10	PIN016	1	PIN, Spring: 3/16
11	CAM003	1	CAM, Lift: upper
12	SCR131	6	SCREW, Button Head
13	SCR089	4	SCREW, Button Head
14	PLT118	1	PLATE, Connector
15	SPG057	1	SPRING, Compression
16	BRK118	1	BRACKET, Assy: 6"
17	SPC033	2	SPACER, Bearing
18	RGR043	2	RING, Retaining
19	SPG056	12	SPRING, Compression
*20	SCR115	12	SCREW, Button Head
*21	BRG007	12	BEARING, Ball
*22	600OUT05	6	OUTLET, Fluid: 3"
*23	SPC030	2	SPACER, Roll
24	RES054	1	RESERVOIR, fluid
A	600VAL04	2	VALVE, Needle
25	600TUB04	2	TUBE, Lubrication: 9"
26	SLV203	2	SLEEVE, Felt: 9"
26	600TUB14	2	TUBE, Smooth: 9" urethane
28	600TUB24	2	TUBE, Textured: 9" urethane
29	PIN021	2	PIN, Rod: quick release

MC-1005 Parts List - 12 inch MiniCoater

Key	Part #	Qty	Part Name
01	FIT115	6	FITTING, Elbow: swivel
02	SPC029	6	SPACER, Duck Bill: check
03	CHK017	6	CHECK, Fluid: duck bill
04	INL046	6	INLET, Fitting: dispenser
05	RGR011	12	RING, Retaining
06	GRD012	1	GUARD, Protective
07	BLK015	6	TUBE, Specify length
08	PIN017	1	PIN, Lift: Upper head
09	FRM012	1	FRAME, Housing: 12 inch
10	PIN016	1	PIN, Spring: 3/16
11	CAM003	1	CAM, Lift: upper
12			NOT USED ON THIS ASSEMBLY
13	SCR089	10	SCREW, Button Head
14	PLT119	1	PLATE, Connector
15	SPG057	1	SPRING, Compression
16	BRK119	1	BRACKET, Assy: 12"
17	SPC031	2	SPACER, Bearing
18	RGR043	2	RING, Retaining
19	SPG056	12	SPRING, Compression
*20	SCR115	12	SCREW, Button Head
*21	BRG007	12	BEARING, Ball
*22	600OUT07	6	OUTLET, Fluid: 4"
*23	SPC032	2	SPACER, Roll
24	RES055	1	RESERVOIR, fluid
A	600VAL04	2	VALVE, Needle
25	600TUB05	2	TUBE, Lubrication: 12"
26	SLV205	2	SLEEVE, Felt: 12"
27	600TUB15	2	TUBE, Smooth: 12" urethane
28	600TUB25	2	TUBE, Textured: 12" urethane
29	PIN022	2	PIN, Rod: quick release

